



MODEL
SERIAL#

4407 Martinsburg Pike
Clear Brook, VA 22624
USA

Phone: 540-662-3811
Fax: 540-665-8101
email: sales@reimersinc.com
web: www.reimersinc.com

R- RH- and RHC-30 Steam Boiler Models (RE-Series)



TABLE OF CONTENTS

Features and Specifications.....	3
Limited Warranty Information.....	4
Important Safety Information.....	5
Installation.....	6
Location.....	6
Water Supply.....	7
Steam Outlet.....	7
Condensate.....	7
Safety Relief Valve.....	7
Electrical.....	7
Operation.....	8
Boiler Startup.....	8
Control Functions.....	9
Boiler Monitor.....	9
Boiler Maintenance.....	9
Boiler Blowoff.....	9
Safety Valve Test.....	10
High Limit Pressure Control Test.....	10
Element Replacement and Element Cleaning.....	10
Low Water Cutoff Test.....	11
Water Level Probe and Probe Baffle Box Cleaning.....	11
Feed Water Pump Replacement.....	12
Gauge Glass Replacement.....	12
Troubleshooting.....	13
Parts Lists.....	14
Parts List (Continued).....	15



RE30 STEAM BOILERS



Features

- Miniature boiler max. vessel volume 1.5ft³
- Maximum safety valve setting 100psi
- All boilers are manufactured in accordance with the requirements of the A.S.M.E. Boiler and Pressure Vessel Code and A.S.M.E. CSD-1. Each boiler bears the National Board Stamp "M".
- High quality saturated steam, operating pressure range 0 – 85psig
- All enclosed sleek design, all controls accessible from boiler front.
- Heavy duty carbon steel pressure vessel. Vessel jacket and electrical enclosure 304 stainless steel.
- Large selection of optional equipment

Standard Equipment of Each Boiler Includes:

- A.S.M.E. pressure relief valve
- One (1) quick opening boiler bottom blowoff valve as per A.S.M.E. Code B31.1
- ½" NPT Bronze steam outlet ball valve
- High pressure feed pump in REH- and REHC-models
- Low water cutoff control with manual reset
- One (1) high pressure cutoff control with manual reset
- One (1) operating pressure control
- Magnetic contactors
- Main supply power distribution block
- Indicator lights for POWER, REFILLING, HEATING, ALARMS and Automatic Boiler Blowoff Status
- Pressure and water level gauge

Applications

- Process Steam
- Autoclaves/Sterilizers
- Air Humidification
- Dry Cleaning
- Air Humidification
- Dry Cleaning

(*) DIRECT STEAM APPLICATIONS TO FOOD PRODUCTS: Reimers offers stainless steel boilers or #OPT1030 Brass/Bronze free boiler trim option (see Page 5). This alone does not guarantee the production of culinary grade steam. Applicable safety standards (i.e. 3-A T609) must be considered.

HEATING POWER KW	STEAM CAPACITY lbs/hr (kg/hr) ⁽⁴⁾	BHP	VOLTAGE ⁽¹⁾	PHASE	SHIP WT. ⁽³⁾ lbs (kg)	PRESSURE VESSEL CAPACITY GAL. (L)	OP. PRESS. RANGE psi (bar)	STEAM OUTLET (NPT)	
								LP <15psig	HP >15psig
10 KW	34 (15.4)	1.0	208/240/380/415/480/600	3 ⁽²⁾	210 (95)	6.8 (25.7)	0 - 85 (0 - 5.86)	1/2	1/2
18 KW	61 (27.6)	1.8	208/240/380/415/480/600	3 ⁽²⁾	210 (95)	6.8 (25.7)	0 - 85 (0 - 5.86)	1/2	1/2
20 KW	68 (30.8)	2.0	208/240/380/415/480/600	3 ⁽²⁾	210 (95)	6.8 (25.7)	0 - 85 (0 - 5.86)	1/2	1/2
30 KW	102 (46.2)	3.0	208/240/380/415/480/600	3 ⁽²⁾	210 (95)	6.8 (25.7)	0 - 85 (0 - 5.86)	1/2	1/2

Model Number Key

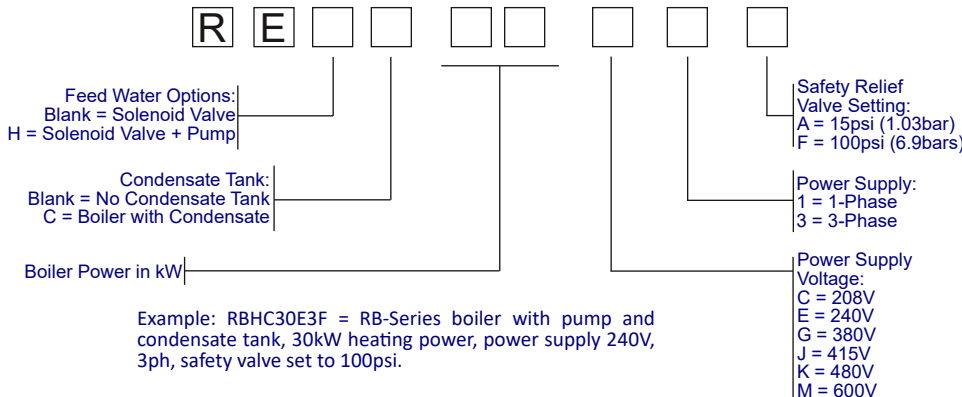

⁽¹⁾ Each boiler model requires two (2) power supplies: Primary heating power and secondary control voltage. Nominal control voltage is 120V, 50/60Hz. Boiler models rated for 380V and 415V are equipped with control voltage transformers that require 220/240V applied to their primary side in order to provide the 120V AC control voltage to the boiler. As an option, all boiler models can be equipped with control voltage transformers so that only the heating power supply needs to be connected to the boiler.

⁽²⁾ Also available in 240V 1PH

⁽³⁾ On boiler equipped with condensate tank, add 90lbs (41.0kg) to shipping weight

⁽⁴⁾ The STEAM CAPACITY listed above is based on the evaporation rate from and at 212°F, at 0 psig. If the boiler feed water temperature is 50°F, then the STEAM CAPACITY for each model listed above is approximately 15% lower.

Please note that all information provided within this brochure is approximate and subject to change without notice. Please contact Reimers Electra Steam, Inc. with any questions regarding the specifications or dimensions detailed within.

LIMITED WARRANTY – STEAM GENERATORS

Reimers Electra Steam, Inc. warrants the following products of its own manufacture against defects in materials and workmanship under normal use and service. This warranty is in lieu and excludes all other expressed or implied warranties or merchantability of fitness for any particular use. No person is authorized to extend the terms of this warranty or assume any other liability except by written statement signed by an officer of Reimers Electra Steam, Inc. Clear Brook, Virginia 22624.

WARRANTY PERIOD

The pressure vessel and electrical & mechanical components are warranted for one year from date of shipment from Reimers Electra Steam, Inc. in Clear Brook, VA 22624.

LIMITATIONS

Products must be installed, used and maintained in accordance with our instructions, including reasonable & necessary maintenance by the user. Users are responsible for the suitability of the products to their application. There is no warranty for damage resulting from improper installation, abuse, power failure, fire, flood, lightening, improper water, misuse, improper specification, misapplication or other operating conditions beyond our control or parts that are normally expendable in usual course of operation.

Claims against carriers for damage in transit must be filed by the buyer. Reimers liability, if any, will not exceed the price of Reimers products claimed to be defective.

Components manufactured by any supplier other than Reimers shall bear only that warranty made by the manufacturer of that product and service for that warranty shall be the responsibility of that manufacturer and not Reimers.

REMEDY

Claims under this Limited Warranty must be made by obtaining a Return Authorization Number from our office (PHONE: 540-662-3811, FAX: 540-665-8101) & returning the defective part, freight prepaid to: Reimers Electra Steam, Inc., 4407 Martinsburg Pike, Clear Brook, Virginia 22624

Defective items will be repaired or replaced as necessary within a reasonable time without charge, other than incidental charges such as freight prepayment. Such repair or replacement within a reasonable time is the exclusive remedy available from Reimers Electra Steam, Inc., under this Limited Warranty.

CONSEQUENTIAL DAMAGES

Reimers Electra Steam, Inc., is not liable for labor costs incurred in the removal, reinstallation, or unauthorized repair of product, or for damages of any type whatsoever, including incidental and/or consequential damages.

THIS WARRANTY SUPERSEDES ALL PREVIOUS WARRANTIES.



Read this manual before installing and using this product. Failure to do so can result in serious injury or death.

You have just purchased a quality steam boiler designed to the ASME Boiler Code and registered with the National Board of Boiler Inspectors. Treat this industrial equipment with care and respect. It is safe when installed, maintained, and used properly. Read the instruction carefully and contact the factory if you have any questions.

This manual contains safety messages. Each of the safety messages are preceded by one of the following signal word panels:



Safety messages preceded by this label contain information, that if not followed will result in death or serious injury.



Safety messages preceded by this label contain information, that if not followed could result in death or serious injury.



Safety messages preceded by this label contain information, that if not followed could result in minor or moderate injury.

NOTICE

Messages preceded by this label contain important information, but are not hazard-related.

Ensure that this manual is available to the boiler operator at any time.

Read carefully all safety labels attached to the boiler. If any safety label was damaged during shipment, contact the factory immediately:

Ph. 540-662-3811; e-mail: sales@reimersinc.com

Important Safety Information



1. BLOWDOWN VALVE: This valve is utilized to blow impurities from the boiler chamber. When opened, a large volume of hot water and steam is discharged. Ensure that this valve is properly piped for such discharge. State and local codes must be met as applicable.

2. ELECTRICAL: All field wiring to the boiler must be in accordance with the National Electric Code and any local codes that may apply. Wiring must be made by a competent certified electrician. Use copper wire only. Ensure that all electrical components are in a dry location, free from any possibility of water soaking. Electric foot switches when supplied must not be placed on a wet floor. They must be placed on dry surface, not subject to steam or water.

3. GAUGE GLASS: The gauge glass protector guards must be on at all times. When replacing the glass, be sure that the unit is not under pressure and is cool to touch. The gauge glass should be replaced once per year. If cracks or wear is evident, replace the gauge glass immediately.

4. MODIFICATION/MISUSE: This boiler has been designed and constructed in accordance with the ASME Boiler and Pressure Vessel Code. Any modification or misuse can result in a dangerous situation. Reimers Electra Steam, Inc. is not liable for any product that has been modified or improperly used.

5. PRESSURE GAUGE: The pressure gauge indicates the internal pressure of the boiler. It can fail. Periodically have your boiler inspector compare the gauge with a known gauge utilizing the test valve arrangement provided

6. REGISTRATION: Most states and cities require boiler registration and inspection. Check with your government authorities.

7. INSTALLATION AND REPAIR:

Installation and repair work of this unit must be performed only by experienced personnel. Before commencing a repair, ensure that the boiler is cold, not pressurized and electrically disconnected. All standard electrical and steam safety precautions must be taken during testing.

8. SAFETY VALVE: The safety valve is designed to discharge hot steam when the set pressure is exceeded. Ensure that the discharge port is pointing toward the back of the unit away from the operator or any aisles. Test the safety valve periodically to ensure that it is operating properly. Test carefully at full pressure by lifting lever using pliers and let it "slapping" shut. Steam discharge can scald. Ensure no one is exposed.

9. STEAM INSTALLATION:

Steam piping must be of black pipe, not galvanized. Work must be done by an experienced steam fitter. All state and local codes must be met as applicable.

10. WATER: Ensure that all electrical components are in a dry location, free from any possibility of water soaking. Electric foot switches when supplied must not be placed on a wet floor. They must be placed on dry surface not subject to steam or water.

1. Installation

REIMERS ELECTRA STEAM, INC. boilers are heated by one or more immersion type heating elements. Automatic controls are provided to maintain pre-set operating pressure and proper water supply. Safety features include automatic low water cutoff, automatic pressure control, safety valve and visible water level gauge. Each boiler is manufactured in accordance with the ASME Power Boiler Code Standards and is individually inspected and stamped by an authorized National Board Insurance Inspector. All boilers are registered with the National Board of Boiler and Pressure Vessel Inspectors. When boiler is received, make sure it has not been damaged in shipment.

NOTE:

ASME DATA PLATE IS LOCATED ON END OF PRESSURE VESSEL BEHIND LABEL STAMPED WITH NATIONAL BOARD NUMBER OF UNIT.

When boiler is received, make sure it has not been damaged in shipment.

1.1 Location

Place the boiler in a level position, close to the equipment which it is to supply. This will insure minimum heat losses and allow more economical piping arrangements. All steam lines should be insulated. Review the overall dimensions of your boiler model on page 6 to select proper boiler location.

Regardless of the NFPA-70 working space requirements shown below, provide a minimum of 3ft clearance on both sides of the boiler for element servicing, 3ft of clearance to the front of the boiler and 1.5ft to the rear of the boiler.

a.) Working space:

Electric boiler spacing is dictated by NFPA-70, Table 110.26 as follows:

Nominal Voltage To Ground (Volts)	Minimum Clear Distance		
	Condition 1	Condition 2	Condition 3
0 – 150	3ft (914mm)	3ft (914mm)	3ft (914mm)
151 – 600	3ft (914mm)	3.5ft (1.07m)	4ft (1.22m)

Note: Where the conditions are as follows:

Condition 1 — Exposed live parts on one side of the working space and no live or grounded parts on the other side of the working space, or exposed live parts on both sides of the working space that are effectively guarded by insulating materials.

Condition 2 — Exposed live parts on one side of the working space and grounded parts on the other side of the working space. Concrete, brick, or tile walls shall be considered as grounded.

Condition 3 — Exposed live parts on both sides of the working space.

(a) *Dead-Front Assemblies.* Working space shall not be required in the back or sides of assemblies, such as dead-front switchboards or motor control centers, where all connections and all renewable or adjustable parts, such as fuses or switches, are accessible from locations other than the back or sides. Where rear access is required to work on non-electrical parts on the back of enclosed equipment, a minimum horizontal working space of 762 mm (30 in.) shall be provided.

b.) *Alcove or closet installation per UL834:* Proper location of this boiler model with regard to combustible and noncombustible surfaces and materials is coded on the boiler name plate. The following decoding sketch and description is provided for the user information:

Model R, RH, and RHC 8-150	Dimension In.						
	A	B	D	EL	ER	F	G
	18	A24	18	18	18	C	-

Description of dimensions and symbols

A – Clearance above top of boiler

B – Clearance from front of boiler

Prefix C to numeral indicates suitability for closet or alcove installation

Prefix A indicates suitability for alcove but not for closet installation

D – Clearance from back of boiler

EL – Clearance from left side of boiler

ER – Clearance from right side of boiler

F – Indicates type of flooring: "NC" for noncombustible floor / "C" for combustible floor. Numeral indicates minimum clearance below suspended units to combustible floor

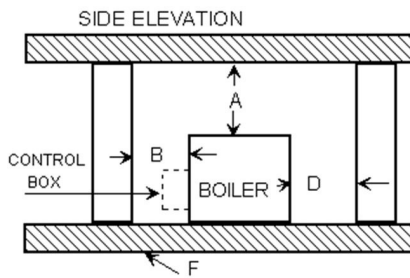
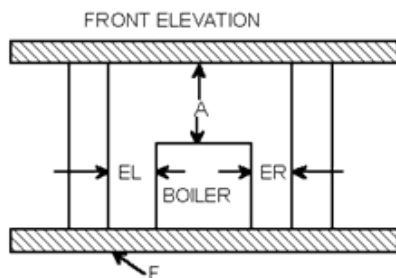

1.2 Water Supply

On models with pump and/or solenoid valve, connect incoming water supply to strainer on intake side of solenoid valve.

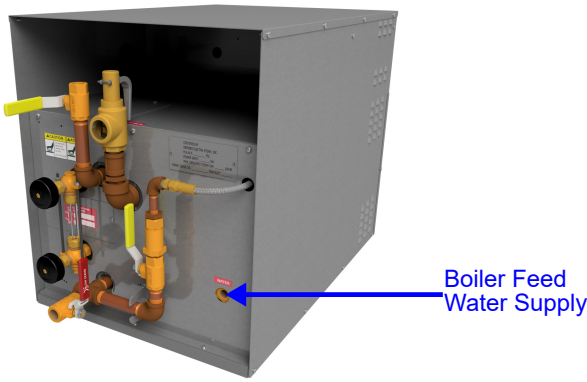

On models furnished with condensate return tank, connect water line to makeup valve located at tank end. (See Instruction Supplement 1 in this manual) R, RH and RHC steam boiler models require four (4) gallons of feed water per hour for each 10 kW of electric heating capacity of the boiler. Lines should be of adequate size and meet local plumbing codes.

In order to ensure long term trouble-free boiler operation, we recommend that the water used as boiler feed water to be tested for hardness. If the water in your area is harder than 1grain (17mg/L), use a water softener. The main cause for premature heating element failure in electric steam boilers is water hardness. If severe corrosion during inspection of the pressure vessel as indicated in chapter 3.4 of this manual becomes evident, additional tests of your boiler feed water must be performed. A water analysis should be performed by a qualified and recognized water treatment company located in your area.

Recommended levels for boiler feed water:

WATER PROPERTY	MAX. LIMIT
Total hardness	17 mg/L
Dissolved Oxygen	0.04 mg/L
Total Iron	0.1 mg/L
Total Copper	0.05 mg/L
pH	> 8.5
Specific Resistivity	25k: * cm

Recommended levels for boiler water (water inside pressure vessel when boiler is operating)

PROPERTIES	MAX. LIMIT
Total Alkalinity	350 mg/L
Total Dissolved Solids	3500 mg/L
Total Suspended Solids	300 mg/L
pH	10.5 - 12

NOTICE

Do not add any chemicals to the boiler feed water unless specifically recommended by a qualified and recognized water treatment company.

1.3 Steam Outlet

Connect steam line of sufficient size from steam outlet valve to the user's equipment.

1.4 Condensate Return

If the condensate is to be returned by gravity (no tank) in a closed system, the load discharge should be at least 2 feet above the boiler level so that the weight of the condensate will actuate the check valve. When applicable, install steam return lines at sufficient height to allow a pitch of 2 inches for every 10 feet of pipe length.

Note: For condensate return systems (with tank), see special sheet.

1.5 Safety Relief Valve

If it is required that discharge piping be installed from the safety valve, the pipe should not be smaller than the valve outlet and should be rigidly supported so as not to place weight on the valve itself.

Important: No valve in this line!

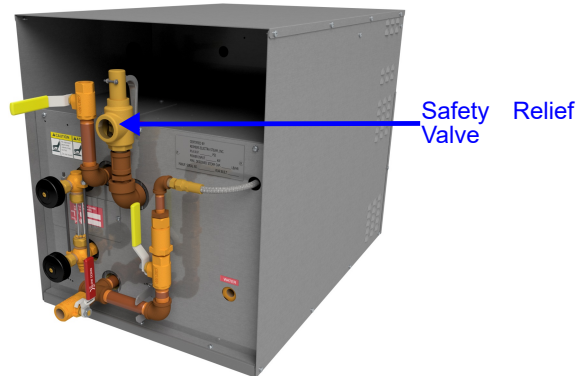

1.6 Electrical

Install a fused disconnect switch near the boiler. It should be fused as marked on the boiler name plate. Connect the power supply from the disconnect switch to the terminals in the boiler control panel.

Important: Electrical connections to the boiler control panel (FIG. 7) should be made by a qualified Electrician. All wiring must comply with local electrical codes.

1.6.1 Three Phase Boiler Models Without Power Supply Extension Box

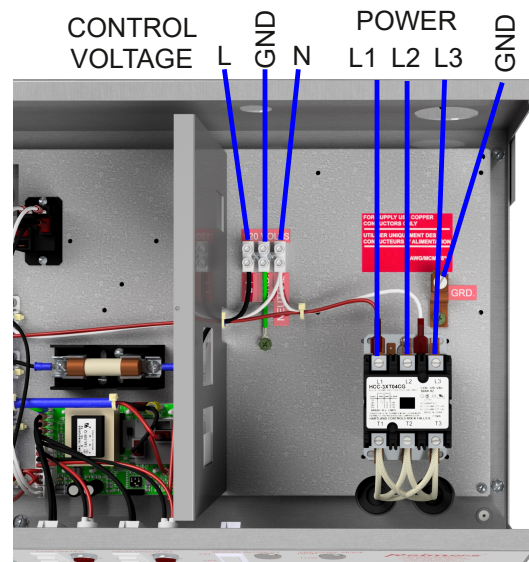

1.6.2 Three-Phase Boiler Models With Power Supply Extension Box

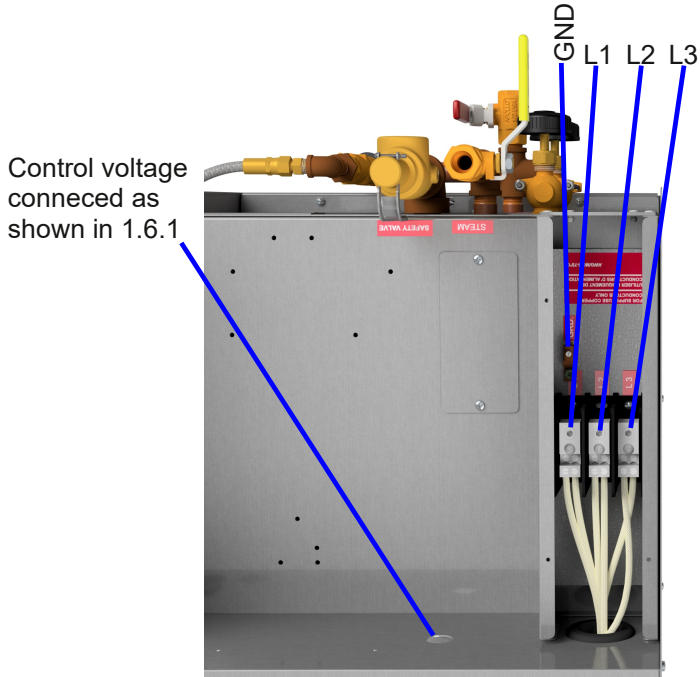

1.6.3 Single-Phase Boiler Models With Power Supply Extension Box

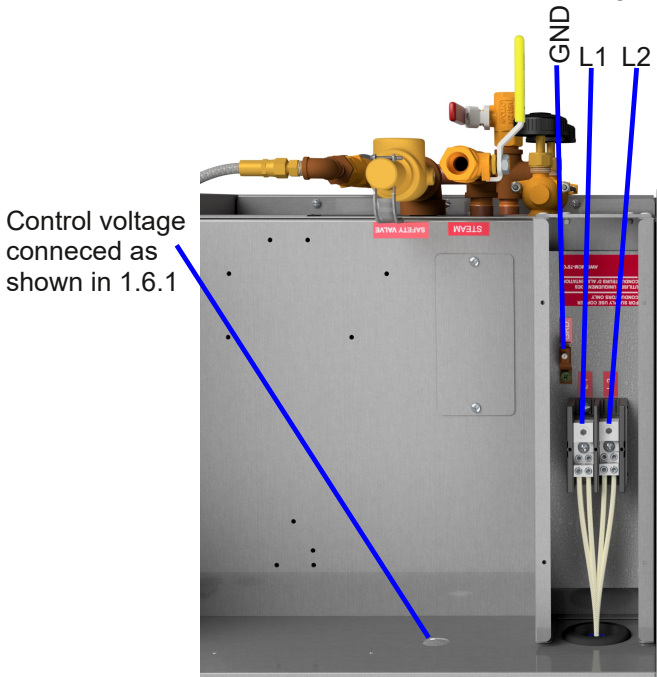

All boiler models that are equipped with a transformer option (OPT1009 or OPT1011) don't require a separate external control voltage power supply.

2. Operation

2.1 Boiler Startup

- Open steam line valve slightly. This will allow the boiler to be filled without producing back pressure.
- Open upper and lower gauge glass fixture valve
- Ensure that the feed water shutoff valve is in the OPEN-position
- Close the boiler blow down valve
- Throw the fused disconnect switch (not provided by factory) to the ON-position and turn on the boiler control voltage

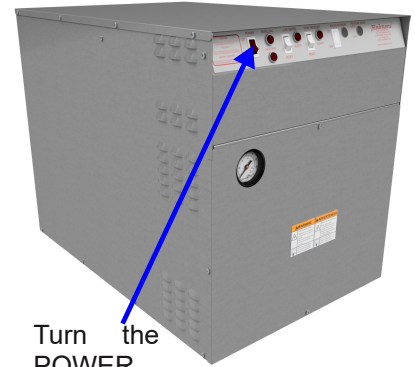
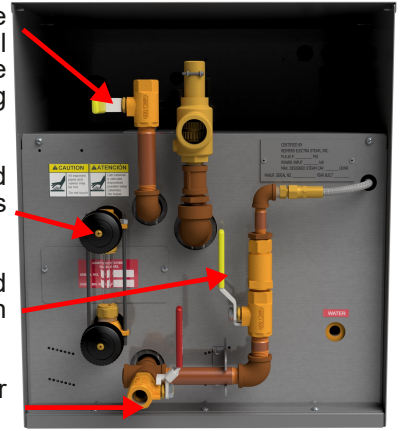

Turn the POWER - switch ON

- After approximately 2 seconds, the WATER FEED light turns on and water enters the boiler. As soon as the water level reaches approximately half height in the gauge glass, the automatic water feed turns off.

NOTICE

Do not let the pump to run dry for an extended time as this will cause damage to the pump.

- If the boiler controller indicates any alarms, then press the corresponding RESET button(s).



As soon as no boiler alarms are indicated, the HEATING light turns on and the boiler starts to build up pressure.

Observe the pressure gauge while pressure builds up, until working pressure is reached. The working pressure should have been factory set to your specification. However, if you wish to change the working pressure setting, proceed as follows.

⚠ WARNING

Stand clear of scalding water or steam. Disconnect the boiler from all power supplies.

All pressure controls are factory preset and require no adjustment. However, if a change of the operating steam pressure is required, then proceed as follows:

- Disconnect all power supplies from the boiler.
- Close the steam outlet valve
- Remove the cover from the pressure control enclosure.
- Turn the black knob of the operating pressure switch clockwise to increase the pressure and counterclockwise to decrease the pressure.
- Connect all power supplies to the boiler, open the steam outlet valve, and install the pressure control enclosure cover.

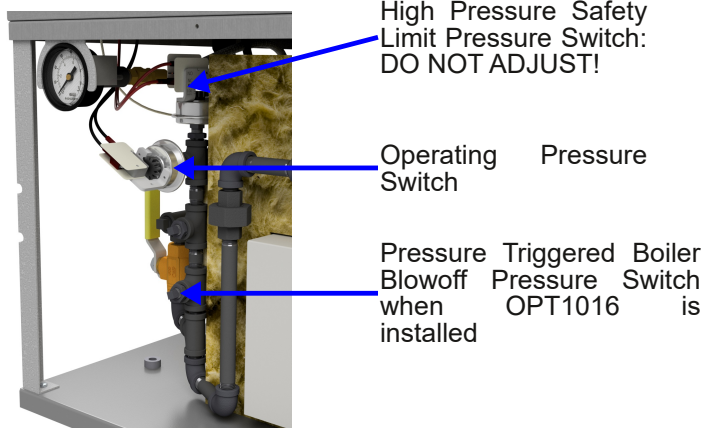

h.) To shut off the boiler, turn the POWER switch on the boiler control OFF

3. Boiler Maintenance

WARNING Boiler repairs must be performed by experienced personnel only. Ensure boiler water is cold and drained and that there is no pressure and all electricity to the boiler is shut-off.

3.1 Boiler Blowoff

All boilers must be blown off periodically to remove minerals, scale and other foreign matter, which accumulate inside the pressure vessel. The concentration of this deposit depends in part upon the condition of the water in the area. When water is naturally soft, or has been softened chemically, boiler blowoffs are required less often than in areas where hard water is found. Water softeners are suggested in hard water areas to minimize the formation of hard scale on heating elements. Another factor affecting water condition is the amount of condensate, if any, that is being returned to the boiler. Since condensate is essentially clean distilled water, it contains very few impurities. If a large part of the condensate is being returned and little make-up water is used, the boiler need not be blown down as often as when little or no condensate is returned to the boiler. We recommend blowoff of newly installed steam boilers once per day until the first heating element and pressure vessel inspection is performed (refer to chapter 3.4). If no significant amount of sediment is found on the bottom of the pressure vessel and on the heating element sheaths, then the boiler blowoff frequency can be reduced accordingly. The safest method to blowoff R-series steam boilers is to install a Reimers Electra

Steam, Inc. properly sized and fully trimmed blowdown tank, model BTANK-10 (Figures 10 and 11). Reimers blowdown tanks are designed and constructed to Section VIII of the A.S.M.E. Code and inspected by a commissioned National Board Boiler inspector.

Refer to the boiler blowdown tank supplement and see: <http://www.youtube.com/watch?v=WhVLOuQywpI>

⚠ CAUTION

3.2 Safety Valve Test

Stand clear of safety valve and scalding steam.

This test should be performed once per month. Proceed as follows:

- Increase the steam pressure as shown in chapter 2.1. to maximum operating pressure.
- Keep the steam outlet valve closed
- Pull the trip lever and hold open for five (5) seconds in order to flush off the valve seat.
- Permit the valve to “slap” shut. If a leak occurs, repeat this test and if necessary, replace the valve.

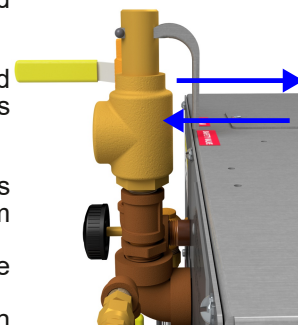

⚠ WARNING

3.3 High Limit Pressure Control Test

Before commencing this test, ensure that the boiler is disconnected from all electrical supplies. This test must be performed by qualified boiler service and maintenance personnel only.

Step 1:

Remove the covers of the enclosure.

Step 2:

Use #18 insulated, 600V rated wire and connect to the operating pressure control terminal as shown in FIGURE 11. This wire will jump the terminals of the operating pressure control.

Step 3:

Turn ON the boiler control voltage and heating power supplies. Ensure that the steam outlet valve is closed.

Step 4:

Flip the POWER switch on the boiler controller panel to the ON-position (FIGURE 12). Ensure that the boiler refills to nominal water level (approximately half height in the gauge glass).

Step 5:

Read the pressure gauge and observe the steam pressure rising. If the boiler is stamped with 15psig maximum allowable working pressure (MAWP), then the high limit pressure control should cut off the heating at 13.5psig. If the steam pressure rises to 15psig, turn the POWER rocker switch OFF immediately. If the

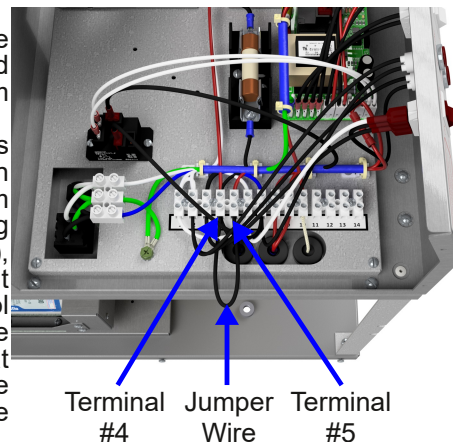

boiler is stamped with 100psig MAWP, then the high limit pressure control should cut off the heating at 90psig. If the steam pressure rises to 100psig, turn the POWER rocker switch OFF immediately.

Step 6:

As soon as the high limit pressure control trips, the HIGH PRESSURE alarm light on the boiler controller terminal turns ON and the HEATING light turns OFF.

Step 7:

Open slowly the steam outlet valve and discharge steam until the boiler pressure drops approximately 4psig on 15psig MAWP models and 10psig on 100psig MAWP models below their cutoff thresholds.

Step 8:

Turn OFF all power supplies to the boiler. Remove the wire jumper from the operating pressure control and install the pressure control enclosure cover.

Step 9:

Turn ON all boiler power supplies. After 2 seconds, the HIGH PRESSURE alarm light should turn ON.

Step 10:

Press the HIGH PRESSURE alarm reset switch. The alarm light should turn OFF.

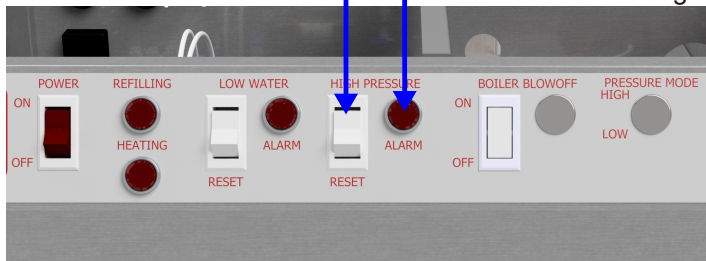

WARNING

If all above steps can be completed as described, then the high limit pressure control works properly

This test must be performed monthly.

DO NOT forget to remove the jumper wire before attempting to resume boiler operation.

3.4 Element Replacement and Element Cleaning

WARNING Ensure that the boiler is cold, drained and all power supplies are disconnected

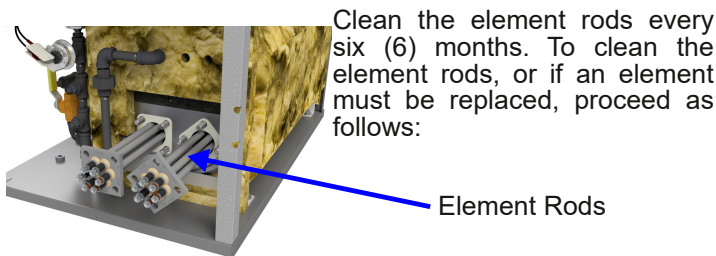

Clean the element rods every six (6) months. To clean the element rods, or if an element must be replaced, proceed as follows:

- Remove the element terminal cover from the front of the boiler.
- Disconnect and label the terminal wires
- Remove all four (4) nuts from each element flange and pull out the heating element
- Use a stiff wire brush to remove all scale and foreign matter from the element rods.
- Clean the element flange surfaces before installing new elements and gaskets

3.5 Low Water Cutoff Test

WARNING Before commencing this test, ensure that the boiler blowoff valve is piped to a blowdown tank

Step 1:

Ensure that the boiler is turned ON; steam outlet valve is closed; the water level is at nominal level (approximately half height of the gage glass) and the boiler at set operating pressure.

Step 2:

Unplug the pump cord if installed from the underside (REH models) or rear (REHC models) of the boiler electrical enclosure, and if installed, the cord from the feed water solenoid valve.

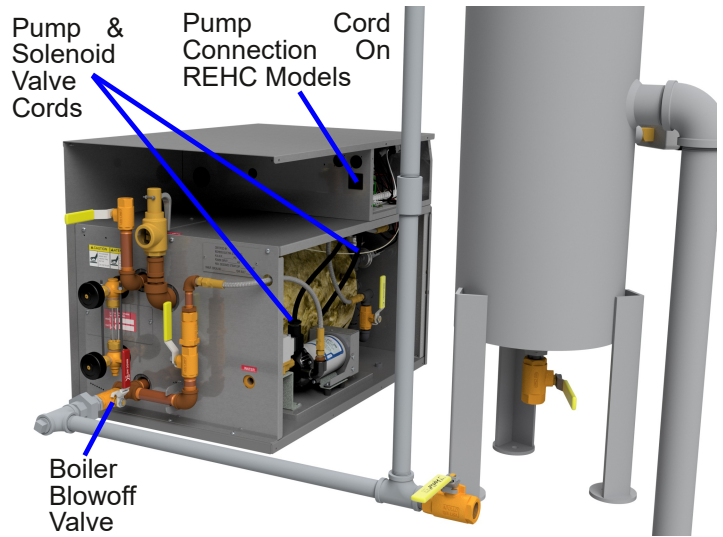

Step 3:

Open slowly the boiler blowoff valve until the water level in the gage glass begins dropping. The REFILLING light on the boiler controller panel should turn ON after dropping the water level about 1/4in.

Step 4:

Keep lowering the water level to the bottom of the gage glass. Depending on the setting of the low water cut off controller, the LOW WATER alarm light may be already lit. If not, wait for a maximum of 1 minute. After the elapse of this time the LOW WATER light should be lit.

Step 5:

Continue blowing down the boiler until empty.

Step 6:

Turn OFF all boiler power supplies and plug in the feed water pump cord and if installed the feed water solenoid valve cord.

Step 7:

Turn ON all power supplies to the boiler. If the control panel indicates a flashing "Low Water", press the Low Water Reset switch to clear. The boiler should start refilling to nominal water level.

Step 8:

Wait until the water level reaches nominal level in the boiler. The LOW WATER alarm light should be still lit and the boiler steam pressure indicated on the gage should be at least 15 psig below the normal operating pressure in high pressure boilers and 5psig below normal operating pressure in low pressure boilers.

Step 9:

Press the LOW WATER reset switch on the controller panel. The LOW WATER alarm light should turn OFF and the HEATING light should turn ON.

If all above steps can be completed as described, then the low water cutoff controller works properly.

NOTICE

This test must be performed weekly.

3.6 Water Level Probe and Probe Baffle Box Cleaning

WARNING Ensure that the boiler is cold, drained and all power supplies are disconnected.

In order to provide reliable automatic water level control, the water level probes are located inside a funnel shaped probe baffle, welded to the inner wall of the pressure vessel. The probe baffle has direct connection to the top and bottom of the pressure vessel so that the probes can read the water level, protected from foam and bursting steam bubbles that form on the surface of the boiler water.

The probe baffle must be cleaned every six (6) months of sediments and other debris that accumulates at the bottom of the baffle. To accomplish this, proceed as follows:

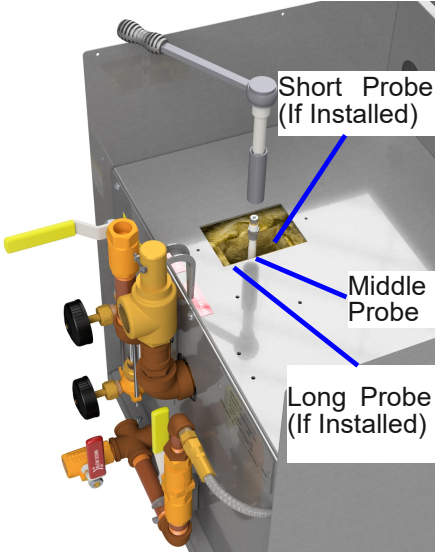

Step 1:

Remove the water level probe cover, disconnect from each probe the wire and label it.

Remove first the Short Probe and inspect the probe rod. If sediment has accumulated, use a stiff wire brush to remove it. Install the probe in its place in the shell.

Repeat the above cleaning procedure for the other probes. Don't install the Long Probe yet.

Step 2:

Insert two (2) 1/4in OD copper tubes or any other soft rods through the Long Probe opening and through the boiler blowoff opening into the pressure vessel to remove sediments from the bottom of the probe baffle.

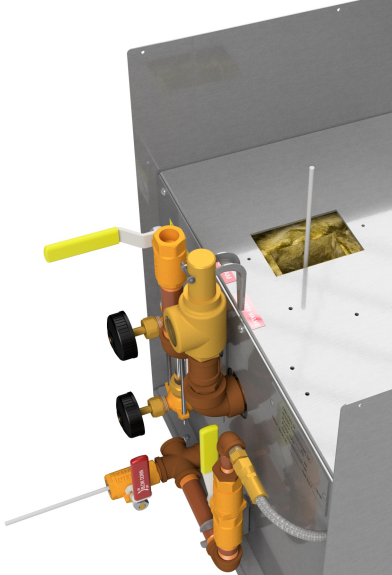

Step 3:

Put a flash light above the Long Probe opening and observe whether light is visible through the boiler blowoff opening. If no light is visible, then repeat inserting the copper tube through the Long Probe opening and pushing towards the bottom to remove further sediment from the probe baffle.

If there is a significant amount of sediment visible at the bottom of the pressure vessel, then the heating elements must be removed as shown in chapter 3.4 and the sediments scooped out through the element openings.

Step 4:

Install the Long Probe into the shell and connect all probe wires.

3.7 Feed Water Pump Replacement

WARNING Ensure that all power supplies are disconnected and that there is no pressure in the boiler.

When replacing the feed water pump on RH-models, proceed as follows (ref. FIGURE 18):

- Unplug the Pump Power Cord (1) of the pump that needs to be replaced
- Close the Feed Water Shutoff Valve (2)
- Disconnect the Pump Ports from the Solenoid Valve (3) and Boiler Water Feed Line (4)
- Unscrew the pump from the pump plate
- Install the new pump
- Open the Feed Water Shutoff Valve (2)
- Turn ON all power supplies to the boiler
- Turn ON the "POWER" – switch of the boiler controller. Observe the water level in the gauge glass and ensure that the pump fills the boiler to its nominal water level
- Close the Boiler Steam Outlet Valve (5) and wait until the boiler reaches its set operating steam pressure

3.8 Gauge Glass Replacement

Step 1



Close gauge glass valves (Top and Bottom)

Step 2

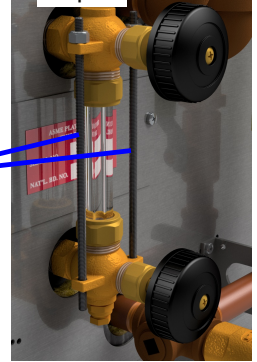

Remove gauge glass protector rods

Step 3



Loosen nuts at top and bottom of glass

Step 4

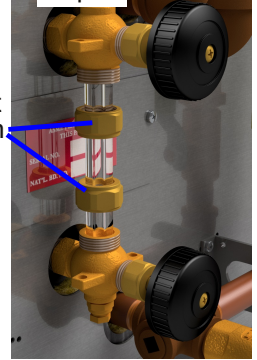

Open drain valve on bottom fixture to drain glass

Step 5

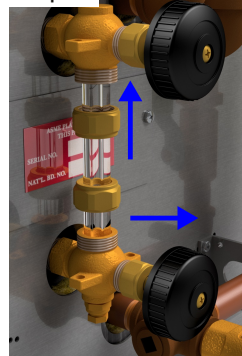

Slide glass up, pull out on bottom of glass and remove

Step 6

Install new glass by performing the above procedure in reverse order. Always install new rubber washers.

4. Troubleshooting



WARNING Ensure that the boiler is cold and has no pressure.
Electrical trouble shooting must be performed by a qualified electrician.

Boiler Status	Quick Fix
POWER switch on boiler controller turned on, but no lights lit on the front panel of the boiler controller	<ul style="list-style-type: none"> - Check circuit breaker or fuse of the wall outlet where the boiler control voltage circuit is hooked up to. If the circuit breaker is tripped or the fuse blown, check whether other appliances are plugged into outlets that are fed by the same circuit breaker/fuse. If that is the case, then plug those other appliances into outlets that are protected by other circuit breakers or fuses.
LOW WATER alarm light on boiler controller panel lit:	<ul style="list-style-type: none"> - Press the LOW WATER reset button - Check Water Level. Water level must be visible in gauge glass. - Ensure that the boiler is filled with Tap water and not distilled or de-mineralized water. - Check the probe wires for continuity
HIGH PRESSURE alarm light on boiler controller panel lit:	<ul style="list-style-type: none"> - Press the HIGH PRESSURE reset switch - If the pressure gauge indicates steam pressure above the preset value, reduce pressure and press the HIGH PRESSURE reset switch again.
Unit won't build up pressure when POWER switch is on, boiler filled to nominal water level with water and HEATING light on the boiler controller is lit.	<ul style="list-style-type: none"> - Voltage Test: Read voltage across each element. If no voltage reading, check the voltage before and after the element contactor. If no voltage before the contactor, check fuses in fused disconnect switch. If no voltage reading after the contactor and contactor pulled in, replace contactor. If voltage reading after the contactor, go to Amperage Test. - Amperage Test: Read amperage on each element wire. If no amperage reading on one or more element wires, replace heating elements.
Pump and/or solenoid valve energized, but no water enters the boiler	<ul style="list-style-type: none"> - Check water inlet strainer - Check whether the water feed shutoff valve is open
Boiler overfills or floods	<ul style="list-style-type: none"> - Check water feed solenoid valve for sticking - Check the probe wires to the boiler controller for continuity - Check feed water. Boiler won't operate with distilled or de-mineralized water
Fuse blown	<ul style="list-style-type: none"> - Short circuit or overload has occurred. Before replacing fuse, locate the short circuit or overload. - Poor contact between fuse and fuse clips can cause fuse to blow. If surface that makes contact with the fuse clips is discolored, fuse has been making poor contact with the clips. Installing a larger fuse will not help. Replace the fuse holder.
Contactor(s) don't pull in	<ul style="list-style-type: none"> - Ensure that the contactor coil is receiving proper voltage - If contactor pulls in but chatters, clean magnetic core of contactor - Further problems would indicate mechanical difficulties within the contactor. - Complete contactor replacement is usually the least expensive solution
"REFILLING" light on the boiler controller is lit, but feed water pump not energized	<ul style="list-style-type: none"> - Check for proper contact of the pump power cord to the receptacle - Check for proper setting of the pump pressure switch. (Refer to chapter 3.6)

If trouble shooting did not resolve problem, please contact our service technicians at:

Phone: 540-662-3811

Email: techsupport@reimersinc.com

5. Parts list for R, RH and RHC Boiler Models (RE-Series)



WARNING Use Reimers replacement parts. All components are designed and approved to be used in this Underwriters Laboratories listed and ASME National Board Stamped boiler. Failure to do so may cause serious injury or death.

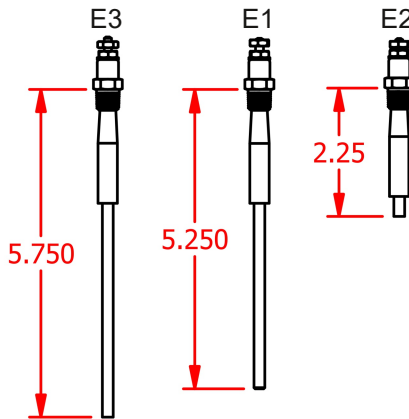
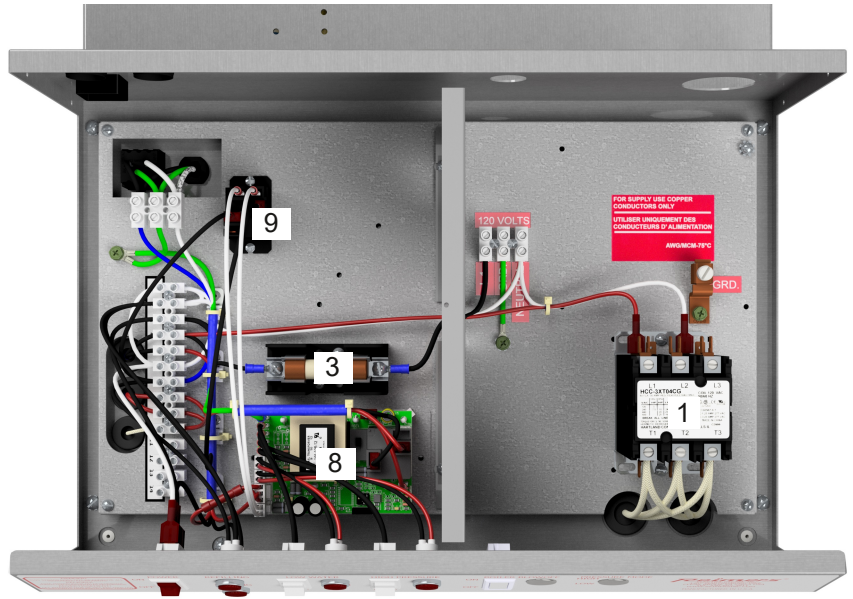
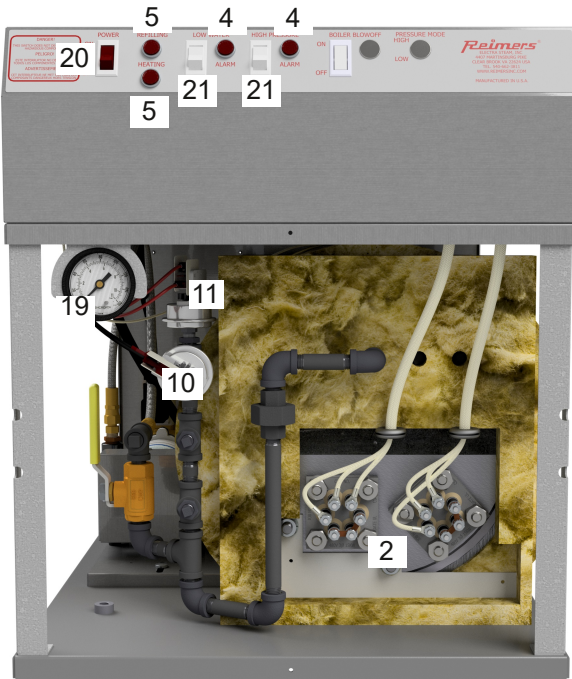

Low Water Cut-Off Probe (E3): Connect this probe to wire marked "14"
 Automatic Refill Probe (E1): Connect this probe to wire marked "13"
 High Water Level Cut-Off Probe (E2): Connect this probe to wire marked "10"
 Please refer also to the boiler wiring diagram and Figure 12 for proper probe identification.

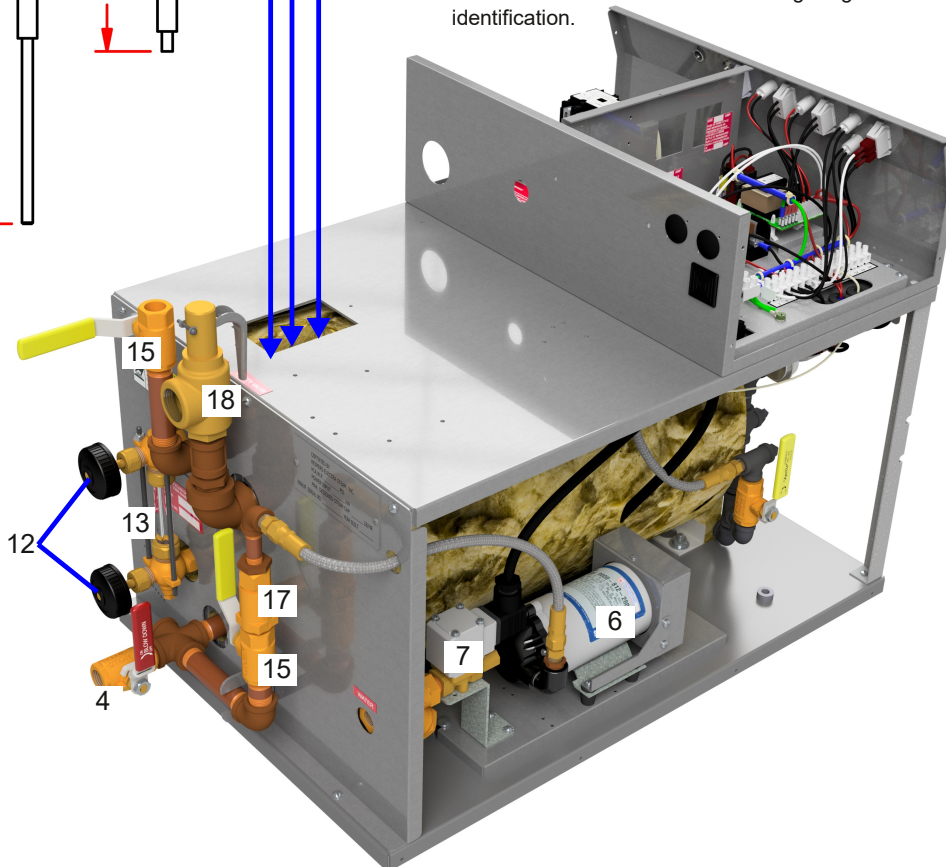

Ref. No.	Wiring Diagram Ref.	Part No.	Description
1	K1, (K2)	02530 02539	Contactora 50A Res. 120V AC Coil Contactora 75A Res. 120V AC Coil
2	HR1, (HR2)	04277 04253 05014 04666 05116 02281	Element 15kW, 208V, 3Ph Element 15kW, 240V, 3Ph Element 15kW, 380V, 3Ph Element 15kW, 480V, 3Ph Element 15kW, 600V, 3Ph Gasket Element
3	F1	02655 02125 02140	Fuse 5A, 250V Fuse 15A, 250V Fuse Block 30A, 250V 1Pole
4		20720	Light Alarm Assembly
5		04396	Light 125V Red Neon W/ Stainless Circular Frame Panel Mount
6	B1	21036 03774	Pump with Cord 120V AC Pump 240V AC
7	SOL1	04761	Solenoid Valve 3/8" NPT 120V AC/DIN-Connector
8	A1/A2	04316-RB	Relay Solid State 120V 30A Programmed For AR-RB
9		04394	Relay SPDT 12V NO 20A/NC 10A
10	S3	04163 04162	Pressure Control Operating 100psi Pressure Control Operating 15psi
11	S4	04296 05077	ii Pressure Control High Limit 15psi Pressure Control High Limit 15psi
12		02396	Water Gauge Set
13		05594	Gauge Glass 5/8" OD x 4.125"
14		02006	Gauge Rubber Washer
15		02490	Valve Ball 1/2" NPT
16		03346	Valve Ball 1/2" NPT w/Latch
17		02370	Valve Check Ball Cone 1/2" NPT
18		02637 02010	Valve Safety 1/2" NPT Valve Safety 3/4" NPT
19		04661 02451	Pressure Gauge 2.0" 1/4" NPT, 0-160psi Pressure Gauge 2.5" 1/4" NPT, 0-30psi
20		04213	Switch Illuminated Red W/White 125/250V
21		03943	Switch manual Reset NC MO