

# BURNER OVERVIEW

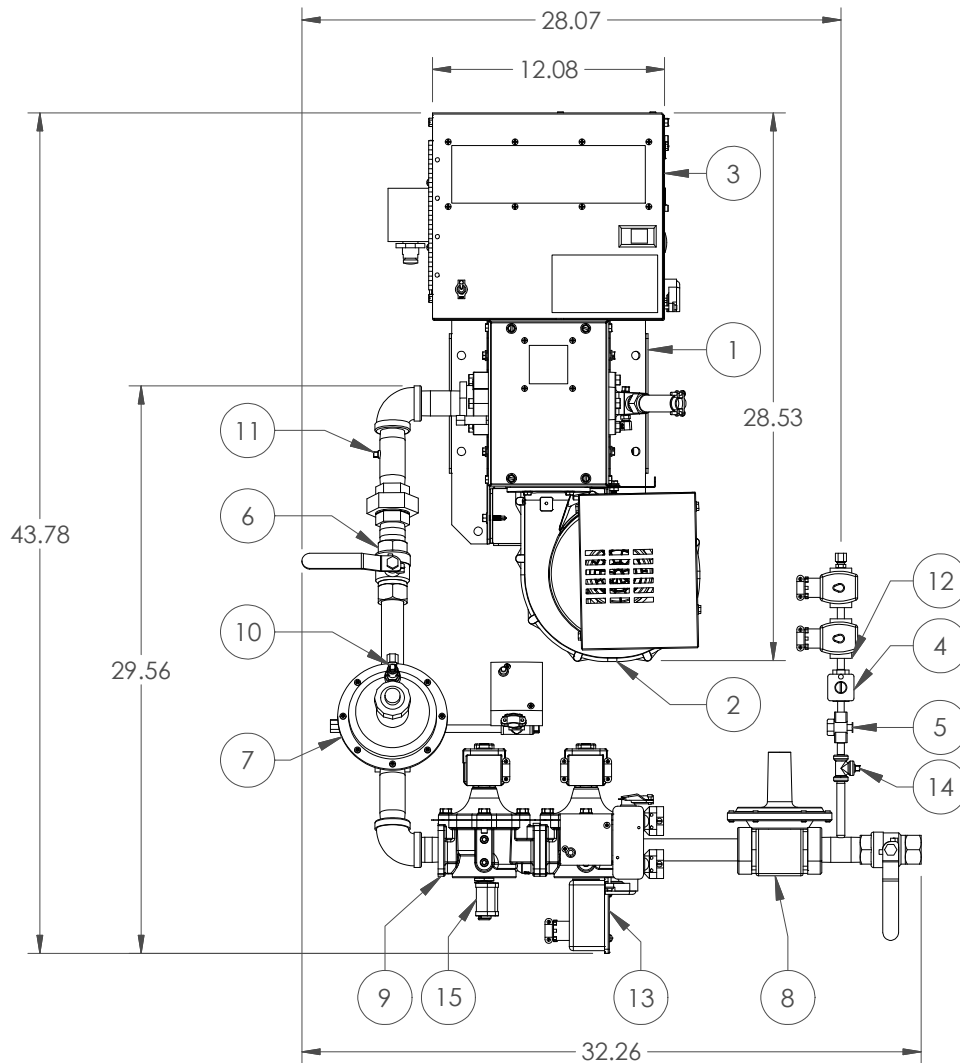

Figure 1 - Complete V1 120V Burner with Valve Train (1405060)

1405060 PARTS LIST		
ITEM	PART NUMBER	DESCRIPTION
1	2100-63	BURNER HOUSING
2	2117-13	VARIABLE SPEED BLOWER
3	2120-15	CONTROL BOX
4	8400-06	PILOT GAS REGULATOR
5	8401-00	1/8" NPT COCK
6	8404-67	MANIFOLD GAS SHUT-OFF VALVE
7	8416-04	DUNGS FRG RATIO REGULATOR
8	8416-33	MAIN GAS REGULATOR
9	8418-11	MAIN GAS SOLENOID VALVES
10	N/A	AIR PRESSURE TAP
11	N/A	MAIN GAS MANIFOLD PRESSURE TAP
12	N/A	PILOT GAS MANIFOLD PRESSURE TAP
13	N/A	PROOF OF CLOSURE SWITCH
14	N/A	SUPPLY GAS PRESSURE TAP
15	N/A	VISUAL INDICATOR

# BURNER HEAD

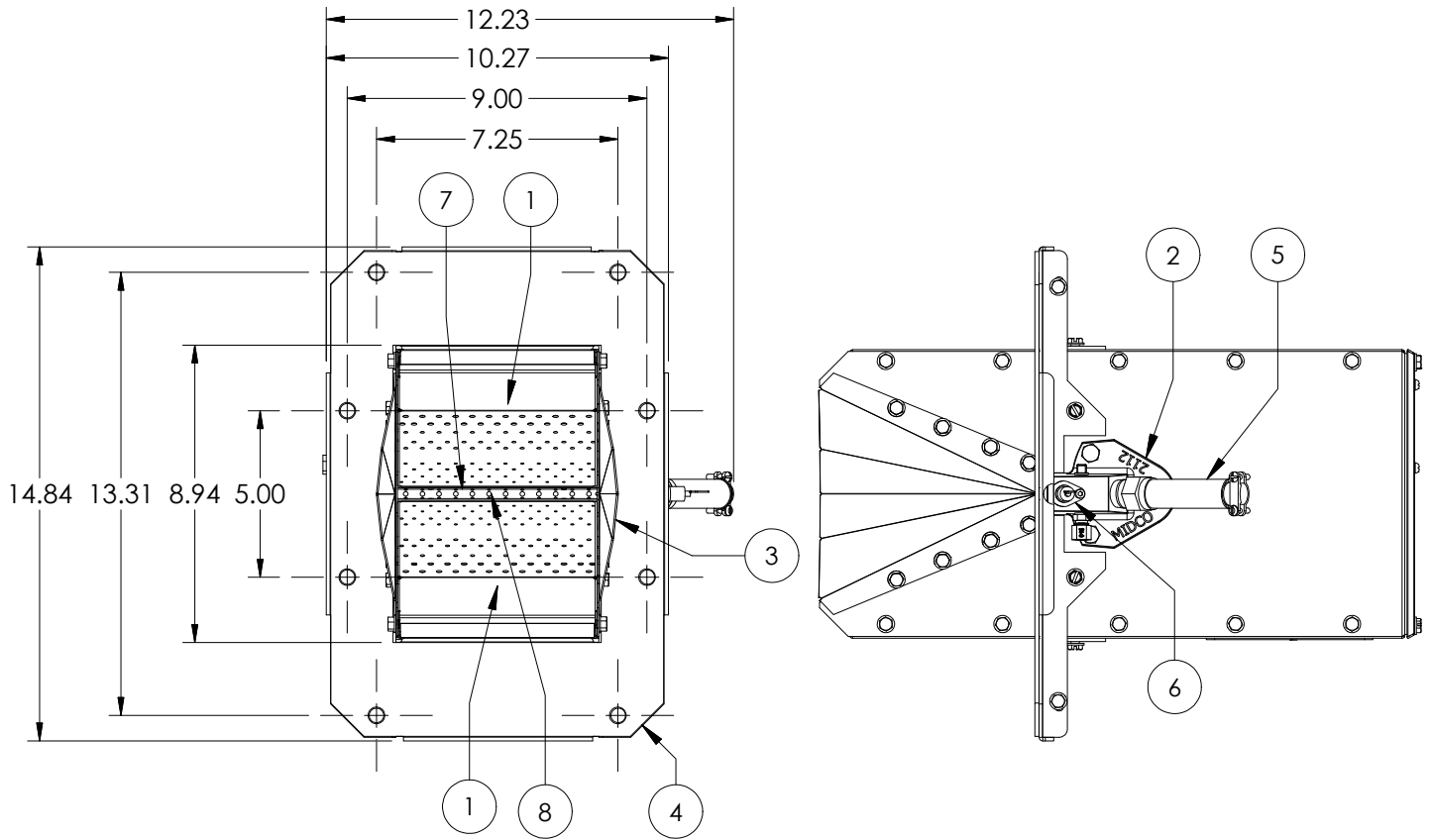

Figure 1 - V1 Burner Housing (2100-62) Side & Front View (End Flange Pilot)

2100-62 PARTS LIST		
ITEM	PART NUMBER	DESCRIPTION
1	2110-00	BAFFLE
2	2112-21	PILOT - END FLANGE
3	2113-50	SIDE PLATE
4	2122-05	HIGH TEMPERATURE FLANGE GASKET
5	8428-05	UV SCANNER
6	8433-21	SPARK ROD
7	N/A	BURNER GAS MANFIELD
8	N/A	GAS ORIFICES

# CONTROL BOX

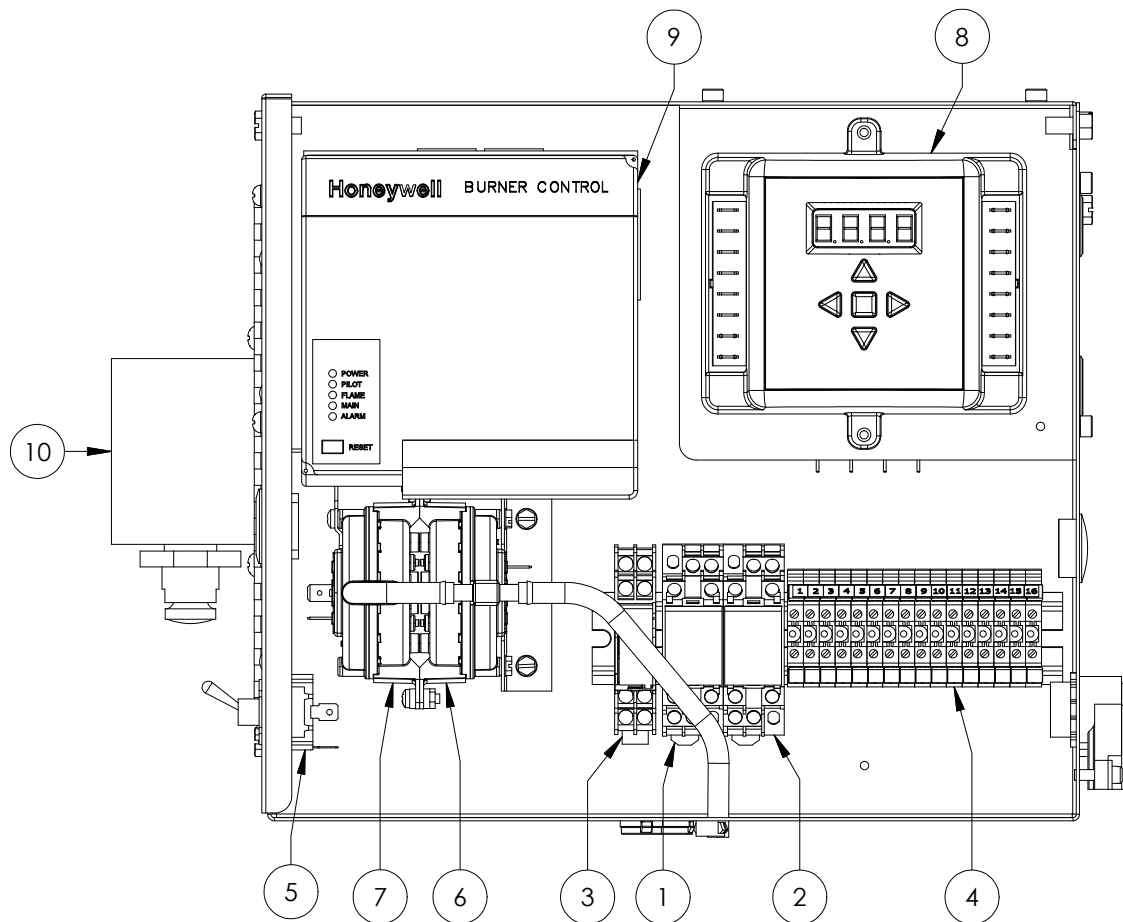

Figure 1 - 2120-15 Control Box

2120-15 PARTS LIST		
ITEM	PART NUMBER	DESCRIPTION
1	8406-95/96	RELAY "B"
2	8406-95/96	RELAY "C"
3	8406-98/99	RELAY "A"
4	8409-25	TERMINAL BLOCK
5	8423-05	ON/OFF SWITCH
6	8425-56	AIR PRESSURE SWITCH, HIGH SIDE
7	8425-56	AIR PRESSURE SWITCH, LOW SIDE
8	8429-78	SCEBM-2 FAN CONTROL
9	8429-81	IGNITION CONTROL
10	8447-22	IGNITION TRANSFORMER

# WIRING DIAGRAM

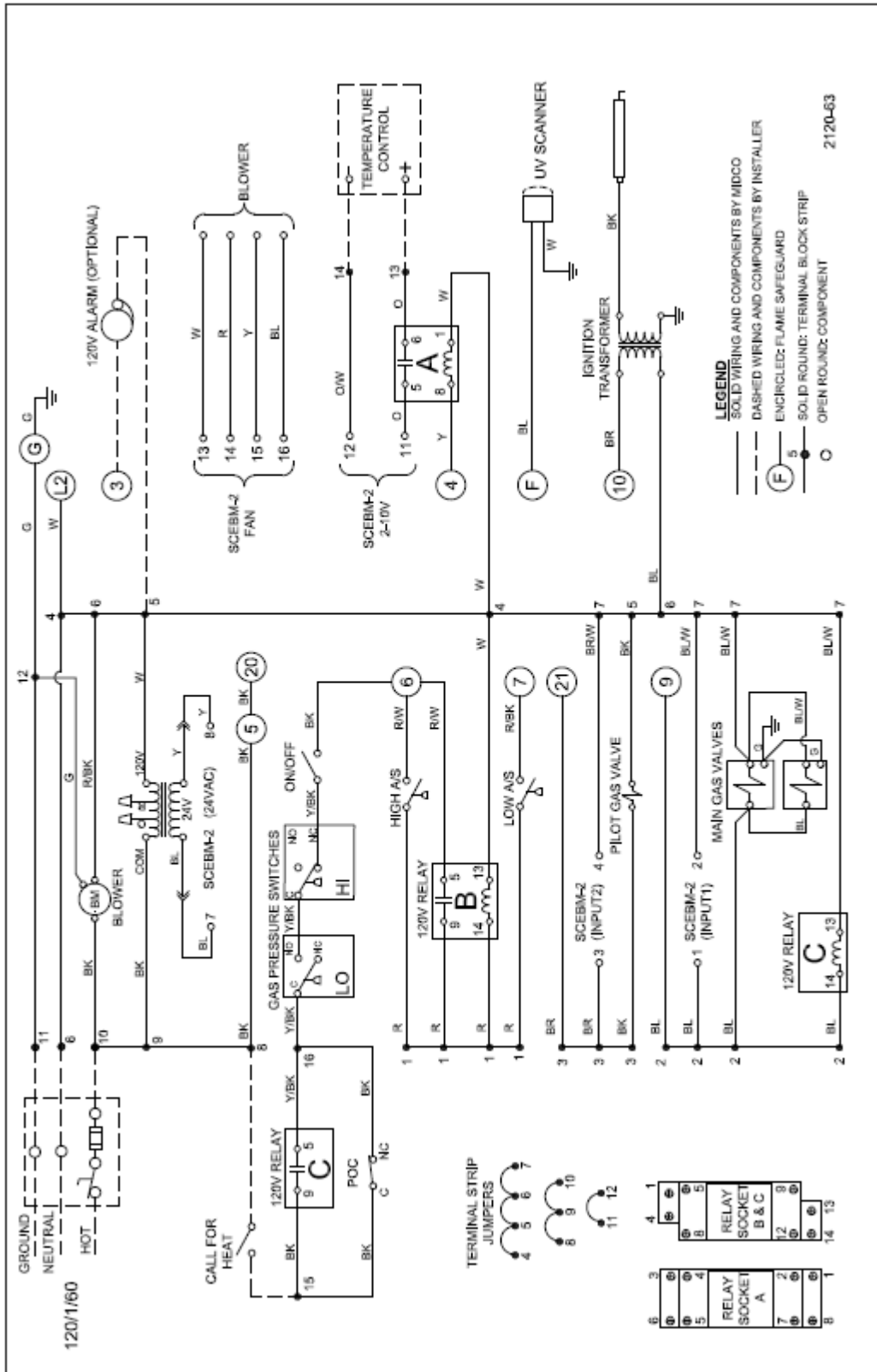

Figure 2 - 2120-63 Control Box Wiring Diagram

# PILOT DETAIL

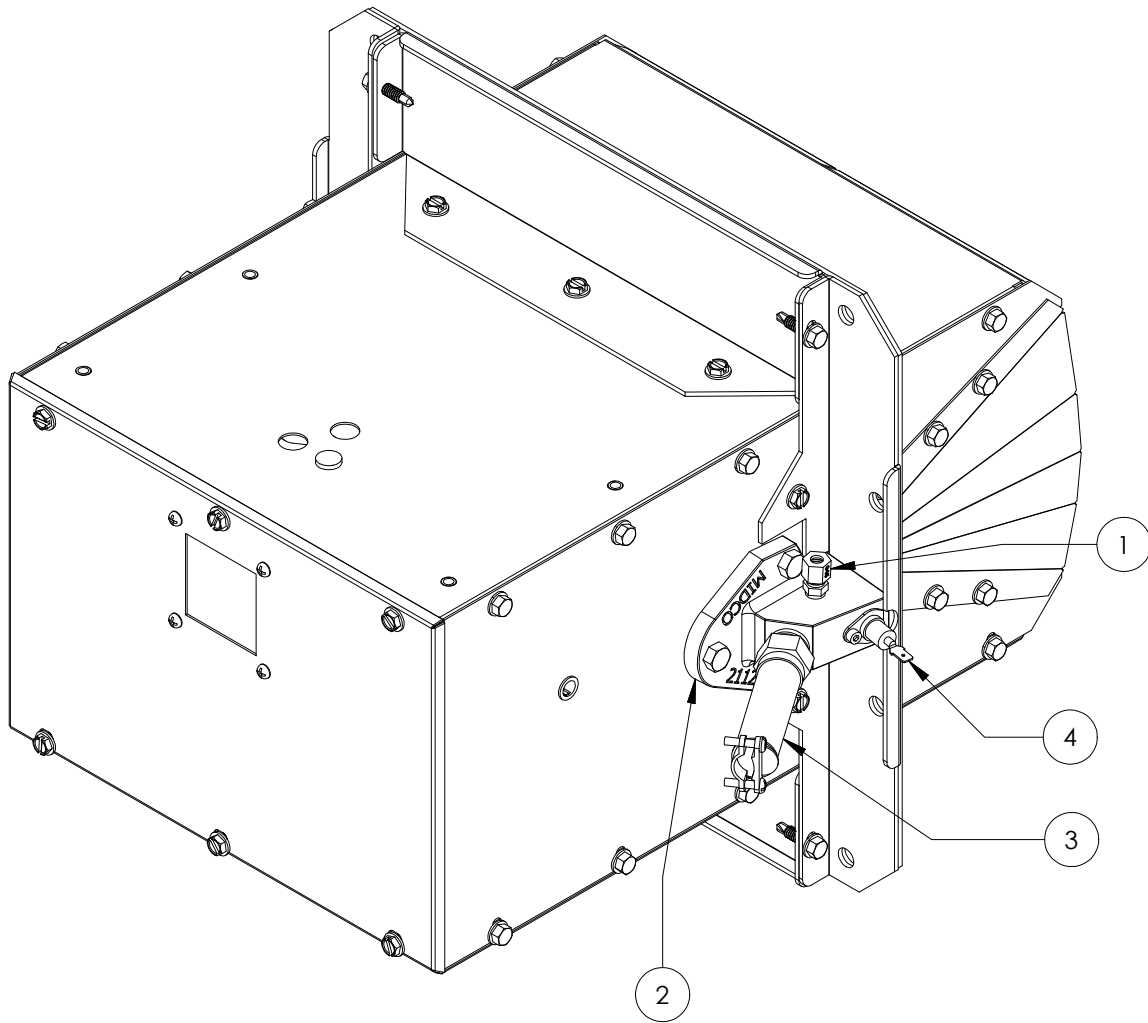

Figure 1 - Burner Housing Rear, End Cap Pilot

PARTS LIST		
ITEM	PART NUMBER	DESCRIPTION
1	2112-12	PILOT ORIFICE
2	2112-21	PILOT
3	8428-05	UV SCANNER
4	8433-21	SPARK ROD