

Powder Coating Enclosure Installation

STEP 1 – Powder Coating Enclosure LOCATION

- This Powder Coating Enclosure is an engineered piece of high-quality equipment and should be treated as such.
- The Powder Coating Enclosure should be located at or above grade and should be on a level floor that is within 1/8" level. If the floor isn't level, the floor track must be shimmed (not provided) during installation.
- Most local code requires a minimum of 3 feet of clearance between the Powder Coating Enclosure and any wall or ceiling.

STEP 2 – CREATE THE FOOTPRINT OF THE Powder Coating Enclosure

- The floor must be level.
- Begin by drawing the layout on your floor with a chalk line. Refer to the drawing section of this manual for the layout.
- Be sure to make sure your layout is perfectly square. You can check this by measuring corner-to-corner (front right to rear left) and then the other corner-to-corner (front left to rear right) and make sure the measurements are the same. If not, you have more of a diamond shape, and the Powder Coating Enclosure will not be square. If the Powder Coating Enclosure isn't square, it will not go together correctly. Check EVERY corner for squareness.
- DO NOT begin installation until the next step(s) are completed.

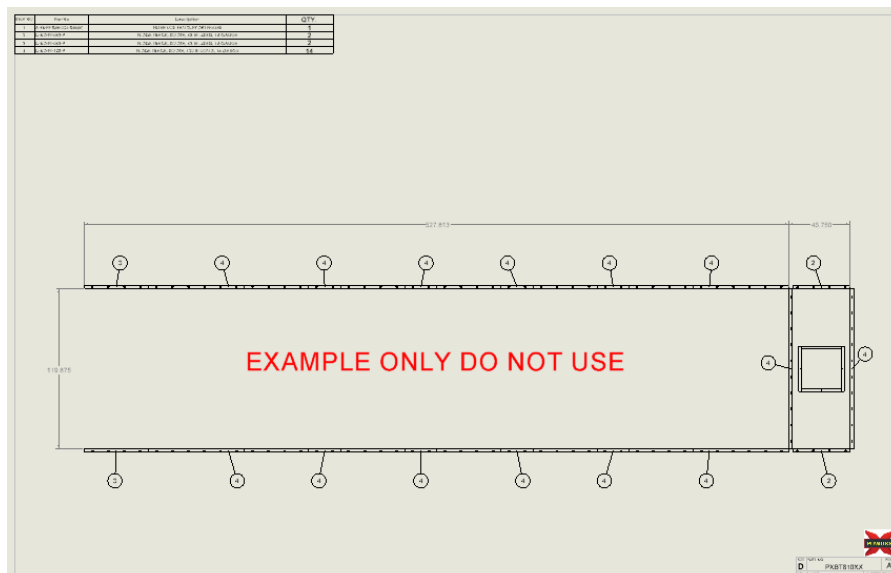

STEP 3 – CREATE THE FOOTPRINT OF THE FILTER BOX

- In the drawing section, locate your filter box location(s). Depending on what you ordered, the box(es) could be located on the end or on the side. See item # 1 in the drawing above for reference. Use your drawing in the drawings section for the exact location.
- Mark your floor for the location of the filter box
- Be sure to make sure your layout is perfectly square. You can check this by measuring corner-to-corner (front right to rear left) and then the other corner-to-corner (front left to rear right) and make sure the measurements are the same. If not, you have more of a diamond shape, and the Powder Coating Enclosure will not be square. If the Powder Coating Enclosure isn't square, it will not go together correctly.

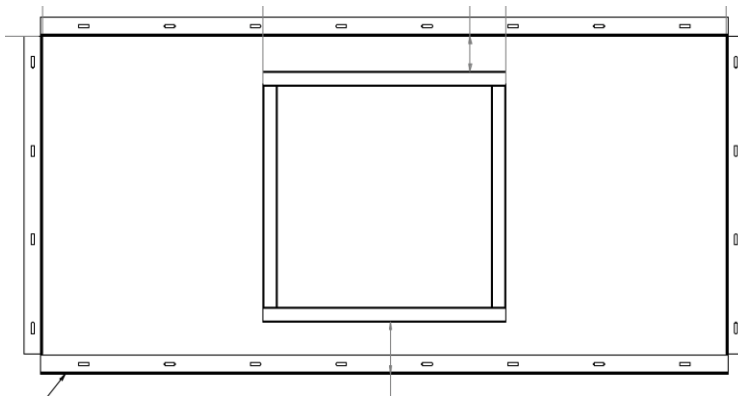

STEP 4 – Lay out the Floor track of the Filter box and build Filter box

- Locate the lower filter box floor track. Look for the drawing like the one above. It will have measurements that tell you the placement of the track.
- Note: The square in the middle of the drawing above is the metal boxed frame that supports the fan.
- The two short side pieces and the rear piece go with the tall lip to the inside of the filter box, as seen below. Position “L” shape floor track to the outside edge of the lines you have on the floor.

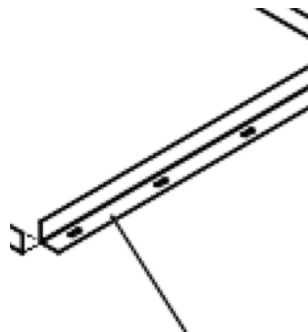

- One long piece (the front of the filter box) goes with the tall lip to the outside of the filter box (to the inside of the Powder Coating Enclosure), as seen below. Position “L” shaped floor track to the inside edge of the lines you have on the floor.
- Attach floor track using provided Industrial Expanding anchors. DO NOT put nuts or washers on yet.

Tall edge to the inside of the Powder Coating Enclosure

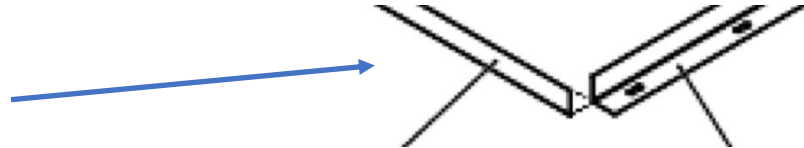

STEP 5 – INSTALL Front Bottom of Filter box

- Locate the front filter box panel. This panel(s) has large square holes.
- Note: Filter brackets are NOT installed before shipping to prevent possible damage. These will be mounted later with provided rivets and rivet gun.
- Set the panel inside the front lip of the filter box floor track. The bottom of the panel should go over the Industrial Expanding bolts in the floor track. Put washer and nut on floor track, thus attaching panel and front track to the floor.
- Using 1/4 #20 1” bolts, attach the bottom front to the tall edge of the floor track.

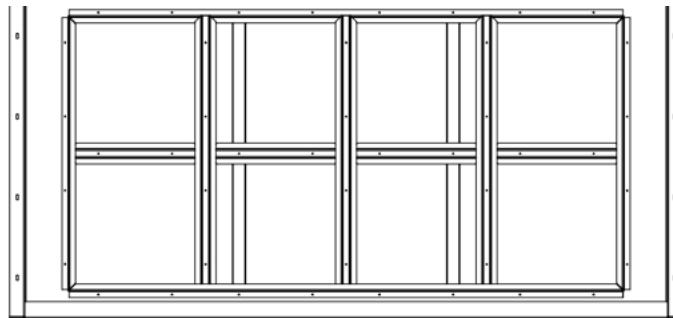

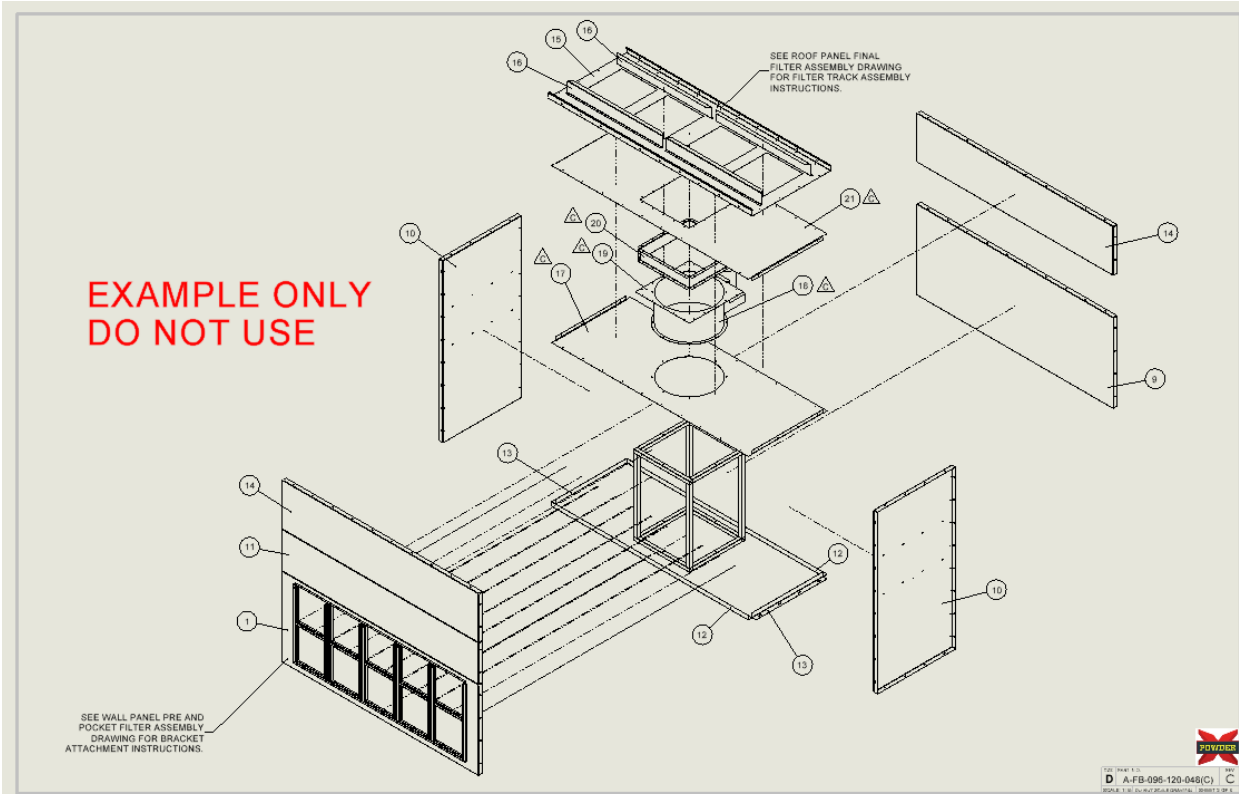

STEP 6 – INSTALL Rear Bottom of Filter Box

- Locate the rear bottom filter box panel. This panel is the same size as the front bottom but has no square filter cutouts. **Be sure to place the side with the larger holes down.**
- Set the panel over the Industrial Expanding bolts in the floor track. The smooth side of this panel goes to the inside of the filter box. Put washer and nut on floor track, thus attaching panel and front track to the floor.
- Using 1/4 #20 1" bolts, attach the bottom front of this panel to the tall edge of the floor track.

STEP 7 - INSTALL FAN SUPPORT PLATES AND Powder Coating Enclosure DUCT FAN

- Locate the duct fan. Note: This step will require multiple people and is most easily done using a forklift.
- Locate the bottom fan plate. It is the same as the top fan plate except the bottom has a large round hole and the top has a large square hole. Both are large sheets with large holes. **HANDLE CAREFULLY with MULTIPLE PEOPLE.**
- Place the bottom fan plate on top of the fan support box. Be sure to turn the flanges on the short side UP.

- Bolt the bottom fan plate to the top of the REAR BOTTOM FILTER BOX PANEL. Do NOT bolt to the top of the FRONT BOTTOM FILTER BOX PANEL.

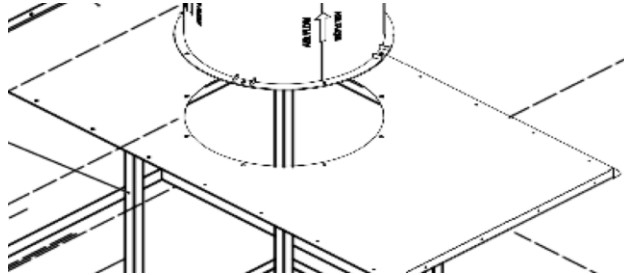

- Carefully place the fan on top of the lower frame assembly. The fan should be blowing up, and the motor will be towards the rear of the Powder Coating Enclosure. See the arrow on the side of fan housing that indicates air direction.
- Align holes in the fan flange with holes in the panel. When standing inside the Powder Coating Enclosure facing to the rear, make sure the motor on the fan is positioned to the left and at 45 degrees toward the rear.
- Locate 3/8 bolts in the hardware box.
- Tightly bolt fan to bottom fan plate using bolts, flat washers, lock washer, and nuts. **Do not skip bolts.**

STEP 8 – INSTALL Front Middle of Filter Box

- Be sure that the Bottom Fan plate is between this panel and the Bottom front panel.
- Bolt these three panels together now.

STEP 9 – INSTALL Fan Transition Adapters and Top Fan Plate

- Install Fan Adapter plate. This part is a flat square plate with a round hole. This hole is the same size as the fan.
- Attach the four fan adapter brackets to the top of the fan adapter plate.
- The top fan plate should lay atop the four fan adapter brackets, while one long edge lays over the front middle panel.
- Make sure the flanges on the short sides are pointing down.
- Do not bolt to the front middle panel yet.
- Align holes in the fan flange with holes in the panel. Using 3/8 bolts, tightly bolt fan to panel using bolts, flat washers, lock washer, and nuts. Do not skip bolts.

STEP 10 – INSTALL Top Front of Filter Box

- Be sure that the Top Fan plate is between this panel and the middle front panel.
- Bolt these 3 panels together now.

STEP 11– INSTALL Side Walls of filter box.

- Set the Side Wall Panel over the Industrial Expanding bolts in the floor track. The smooth side of these panels goes to the inside of the filter box.
- Put washer and nut on floor track, thus attaching panel and track tightly to the floor.
- Using 1/4 #20 1" bolts, attach side walls to the front, bottom, middle, and top filter box panels.

STEP 12 – INSTALL Top Rear of Filter Box

- Bolt the bottom of this plate to the Top Fan plate
- Depending on the number of final filters, this panel may or may not have large square holes.
- Bolt this panel to the two side walls

STEP 13 – INSTALL Filter Box Roof Panel (Final Filter Panel)

- This panel has large square holes.
- Note: Filter brackets are NOT installed before shipping to prevent possible damage. These will be mounted later with provided rivets and rivet gun.
- This panel should be laid with the flanges on the LONG sides facing up. The Powder Coating Enclosure roof panel will attach to the front edge of this panel.
- Using 1/4 #20 1" bolts, attach to the top of the side walls. The top of the Front Top Filter Box Panel and to the top of the Rear Top Filter Box Panel.

STEP 14 – CAULK and INSTALL Filter Brackets Filter Box

- Using clear caulk (not provided) caulk EVERY SEAM of your collector box. This includes where the track meets the floor and where panels meet.
- These must be caulked inside and out to validate the warranty.
- Locate rivet gun and rivets
- Scan the QR code on the front of the Powder Coating Enclosure Control Panel for Technical Support and locate the video for Filter Bracket Installation. This video will show how to install the filter brackets.

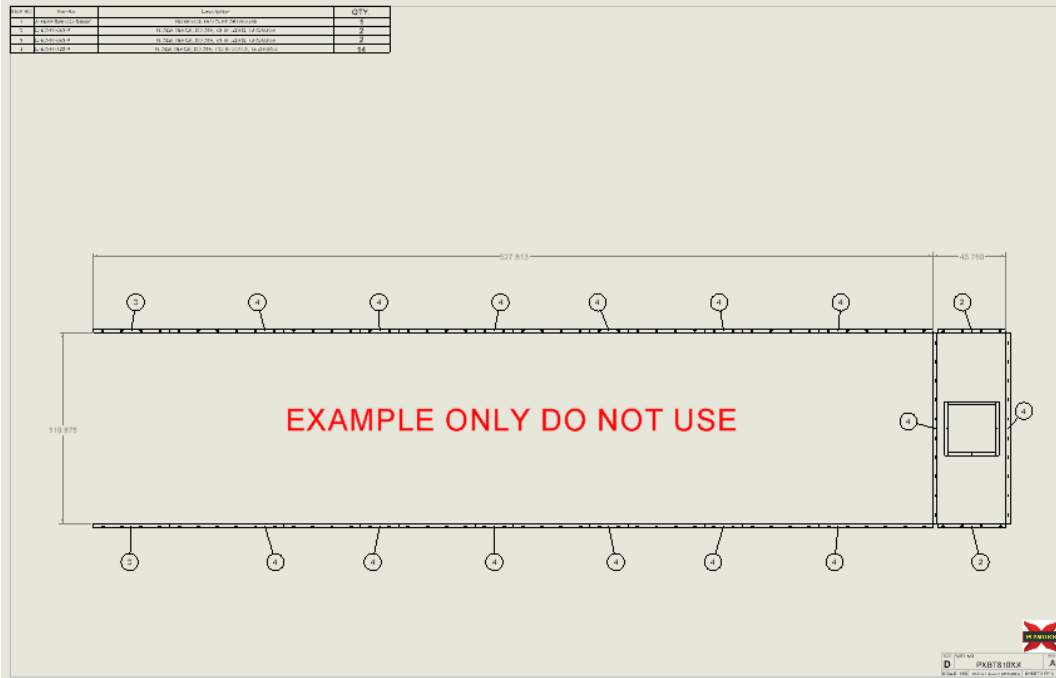

STEP 15 – INSTALL Powder Coating Enclosure FLOOR TRACK

- If the plenum is on the side OR if the Powder Coating Enclosure is wider than the plenum, the Powder Coating Enclosure will have True-X Corner Tracks. If not, it will not have them. Reference the drawing section for your layout. An example of the floor corner is item #5 in the above example drawing. The drawing above is **THIS IS JUST AN EXAMPLE - SEE YOUR DRAWING.**
- Position the corners flush with the filter box frame and aligned with lines on the floor. The track should lie to the outside edge of the lines that you have on the floor. The tall lip with the bolt hole goes to the inside of the Powder Coating Enclosure.
- Once a corner is positioned and square locates holes in the corner flange.
- Find the Industrial Expansion Anchors in your hardware box.
- Insert Industrial Expansion Anchor into the drilled hole. Using a hammer, drive down until flush.
- Using a socket, tighten the bolts of the Industrial Expanding Industrial Fasteners. **Do not overtighten.**
- Locate the remaining floor track. Be sure to position the “L” shaped floor track to the outside edge of the lines you have on the floor with a tall lip with bolt holes to the inside.
- **NOTE: Before anchoring the floor track, ensure the track is level. The track dictates how to level the Powder Coating Enclosure and will have a MAJOR effect on the level of difficulty in bolting together moving forward. Use shims, if necessary, but the track MUST BE LEVEL.**
- Repeat using Industrial Expanding fasteners.

- Review each panel as it is attached to ensure no gaps or cracks are located between track and floor.
- Use clear caulk (not provided) to fill areas seams in contact with the floor

STEP 16 – INSTALL WALL CORNER (IF NEEDED)

- Depending on the size and configuration of your enclosure, it may come with prefabricated corners. These are referred to as True-X Enclosure Corners.
- If your Powder Coating Enclosure has True-X Corner Floor Track, it will have True-X Powder Coating Enclosure Corners. Locate the True-X wall corner if necessary.
- Refer to the supplied drawings on the configuration of your exact Powder Coating Enclosure.
- Remove the nuts from the Industrial Expanding anchors on the corner floor track.
- Position the corner on top of the floor track corner and replace the washer and nut and tighten, **DO NOT over-tighten.**
- If the unit is over 12' tall, you will have to attach the second corner panel into the lower corner using ¼-20 x 1-inch bolts, flat washers, lock washers, and nuts. **Do not skip the bolt.**

STEP 17 – INSTALL WALL PANELS

- Locate wall panels.
- Depending on the Powder Coating Enclosure size, wall and/or ceiling panels may consist of both a long and a short piece.
- Refer to the supplied drawings on the configuration of the wall panels.
- **NOTE: IF walls and/or ceilings panels are a 2-part construction (a short and a long), always stagger the seams. SEE THE EXAMPLE BELOW.**

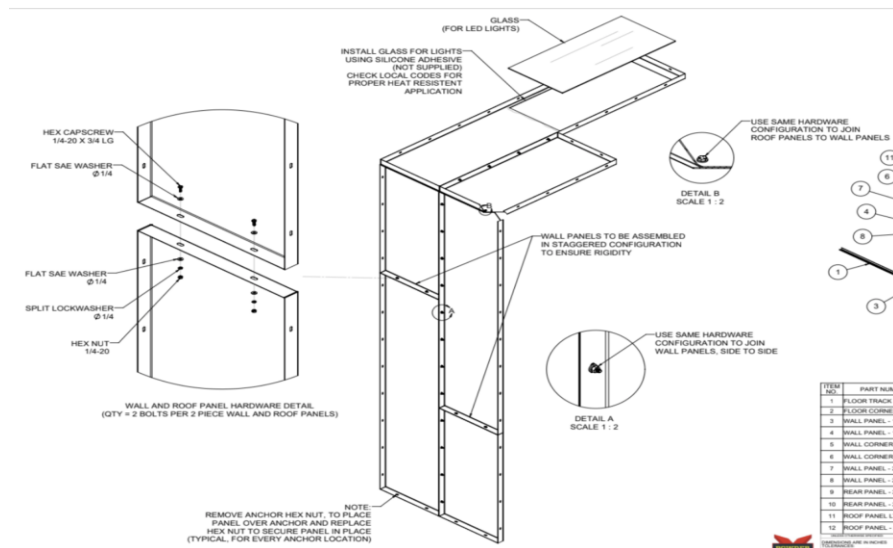

- Remove the nuts from the Industrial Expanding anchors on the floor track.
- Position the wall on top of the floor track and replace the washer and nut and tighten, **DO NOT over-tighten.**
- If the unit is tall, you will have to attach the second panel using ¼-20 x 1-inch bolts, flat washers, lock washers, and nuts. **Do not skip holes, and DO NOT over-tighten**
- As you move along, make sure the walls are rigid and straight. Use a level.
- Position two sets of wall panels on each side of the Powder Coating Enclosure. Once two walls are installed on each side, see step 12 below and install roof panels on these walls. You would build wall panels and roof panels together as you move forward so that the Powder Coating Enclosure remains rigid.
- Review each panel as it is attached to ensure no gaps or cracks are located between panels.
- **NOTE: Use clear caulk (not provided) to fill the seams inside the Powder Coating Enclosure - walls, roofs, and where they meet.**

STEP 18 – INSTALL ROOF PANELS

- Locate roof panels.
- Refer to the supplied drawings on the configuration of the roof panels. Pay close attention to the location of the light panels.
- Sit the Rear Roof Panels in place. Make sure everything is SQUARE before anchoring. Once these panels are anchored, they will dictate the squareness of the roof moving forward.
- Using ¼-20 x 1-inch bolts, attach the Rear Roof Panels to the top of the wall panels. **DO NOT SKIP BOLTS. Ensure plumb, level, and square and tighten firmly.**
- Bolt to the Filter Box assembly
- Review each panel as it is attached to ensure no gaps or cracks are located between panels and frame or other panels.
- Once the first set is secured, repeat Step 11.
- Refer to the supplied drawings on the configuration of the roof panels. The light hole roof panels position is designed for the best lighting.

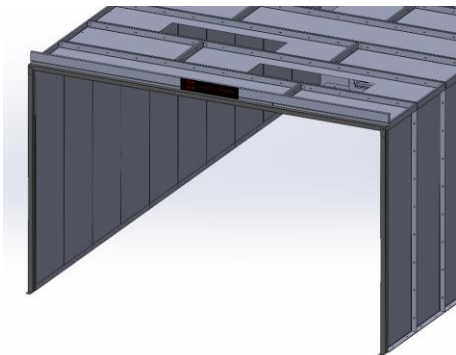

STEP 19 - INSTALL FRONT FRAME

- Locate FRONT frame assembly. If you ordered filtered doors, these frames would have welded hinges.
- Powder Coating Enclosures have an optional filter door. If your unit has a door, see step 14 for door installation.
- Door frames consist of two vertical leg posts and a horizontal post.
- Vertical leg posts have a tab welded on the bottom, and tabs are positioned on the floor.
- Position the vertical leg to assemble with the tab facing away from the Powder Coating Enclosure opening and the frame flush with the inside of the Powder Coating Enclosure wall.
- Using a 4' or larger level, ensure each leg is level and plumb.
- Once each leg is level and plumb, locate the large box of #10-16 self-tapping screws in your hardware box.
- Using a drill with a hex head attachment, install self-tapping screws through the holes in the sides of the wall panel flange and into the leg assembly. **DO NOT SKIP SCREWS.**
- The tab will be attached to the floor.
- Find the Industrial Expansion Anchors in your hardware box.

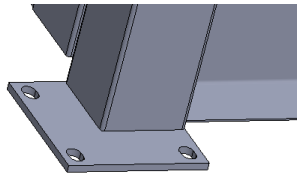

- Insert Industrial Expansion Anchor into the drilled hole. Using a hammer, drive down until flush.
- Using a socket, tighten the bolts of the Industrial Expanding Industrial Fasteners. **Do not overtighten.**
- Repeat on the other side
- Locate cross support tube.

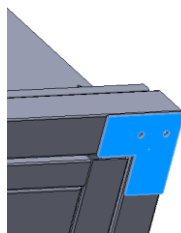

- Position it on the top of the leg assemblies. Behind the tab on the top of the leg.
- Validate that intersection between the leg and cross support tube is square and level.

- Be aware that the cross-support tube will have a door stop in the middle. Position it down and toward the inside of the Powder Coating Enclosure.
- Using a drill with a hex head attachment, install self-tapping screws through the holes in the roof panel flange, into the cross-support tube, and in the leg assembly and cross-support tube tabs. **DO NOT SKIP SCREWS.**
- If the roof is not level, push it up or down before screwing it to the cross-support tube.
- Review each panel as it is attached to ensure no gaps or cracks are located between panel and frame.

STEP 20 – DOOR INSTALLATION (optional)

- Locate door assemblies.
- Place O-ring spacers on the hinge pins on the door frame opening. **You will find these in a bag in the hardware box.**

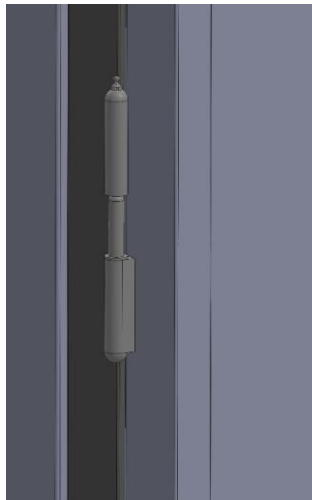

- Stand the door frame up and move to the door opening.
- Installing the door frame is accomplished by lining up the door hinge with the door hinge pins on the opening frame.
- The doors open out and should be hung accordingly. Pay attention to which is the right-hand and left-hand door.
- Check the door swing and make sure they open smoothly without any rubbing on the floor or frame. Adjust accordingly.
- Locate the door latches located in the hardware box. They are similar to the latch for the oven but only smaller. Instead of attaching it to the header like on the oven, you can place one on each door.
- These will be mounted on the door frame opening above the right door. They should be able to catch the right door when closed toward the center of the opening.
- This will be attached to the frame opening with ¼-14 x 1.25 self-drilling screws located in the hardware box.

STEP 21 – INSTALL HEADER AND LOGO

- Locate header panel(s).
- Position header panel(s) front and on top of the cross-support tube. Align ends with the solid side of the panel facing out. The surface will be flush with the front of the door frame assembly. The Header Panel must be mounted for code compliance.
- Reference drawing for proper orientation and alignment.
- Using a drill with a hex head attachment, install self-tapping screws through the holes in the header panel and into the door frame tube from the top. **DO NOT SKIP SCREWS**

STEP 22 – INSTALL CONTROL PANEL

- Control panel must be installed per local code. The panel can be located on either side of the Powder Coating Enclosure in the most convenient location. It is recommended that a disconnect as determined by local code be wired between the Powder Coating Enclosure control panel and the supply power.

STEP 23 – INSTALL LIGHTS

- NOTE: The glass MUST be sealed to the Powder Coating Enclosure with either double-sided tape (not provided) or some other sealant as dictated by local code. Different municipalities may have different sealant requirements. NOTE: It is VERY IMPORTANT that you seal the glass to the Powder Coating Enclosure.
- Put double sided tape or sealant (Per local code) around the light holes. Carefully lay the glass over the light holes.
- Allow glass to sit for 4 hours before installing the lights. This gives it time to seal.
- Lay the lights atop the glass.
- Your licensed electrician can now wire the lights to the control panel per the electrical schematic.

STEP 24 – HAVE A LICENSED ELECTRICIAN WIRE Powder Coating Enclosure

- Wiring schematics are provided in this manual. A licensed electrician is required to pull and land all interconnect wiring and main wiring. The license number, name, and contact information will be required on the Warranty Validation Form. Failure to use a licensed electrician will void the warranty.

STEP 25 – HOOK UP THE MAGNEHELIC PRESSURE GAUGES - VERY IMPORTANT

- Go to CHAPTER 6 - SECTION b. of this manual. The 2 magnehelic gauges need to be hooked up correctly.
- Look on the bottom of the control panel. There are air connections labeled MAIN, OPEN, and FINAL. Also locate the black through-wall fittings.



- You will need to drill a hole in the wall of the booth behind the pocket filters. Attach the black fitting. Then run the RED airline from this point to the port that is labeled MAIN
- You will need to drill a hole in the wall of the booth above the fan but below the final filters. Attach the black fitting. Then run the RED airline from this point to the port that is labeled FINAL.

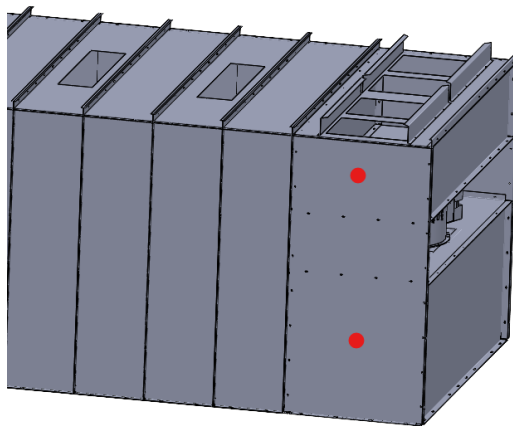

- The above drawing is the preferred location of the holes horizontally and vertically, but need to go in the wall panel closest to the control panel
- IMPORTANT NOTE: When operating the Powder Coating Enclosure, the filters MUST be replaced when the gauges call for it. Only factory authorized filters can be used for warranty compliance. **KEEP IN MIND - Some filters have up to a multiple week lead time based on demand and supply chain. Keep one set of filters on hand to avoid shutdown.**
- These gauges are pre-set during assembly of the control panel. If the settings need calibration, use the manual in Chapter 6 - Section 6 for instructions. Set the gauges to the setting shown on the front of your control panel.
- NOTE: When MAIN FILTERS get loaded with too much powder, the ALARM light on the control panel will indicate that it's time to change the filters. Filters MUST BE CHANGED and

CANNOT BE CLEANED. Filters must be replaced with factory authorized replacements only so as not to void your warranty.

- NOTE: When FINAL FILTERS get loaded with too much powder, the ALARM light on the control panel will indicate that it's time to change the filters. The booth will also shut down the fans. Fans will not run with loaded final filters. Filters MUST BE CHANGED and CANNOT BE CLEANED. Filters must be replaced with factory authorized replacements only as to not void your warranty.

STEP 26 – PERFORM ALL READINGS AND SUBMIT WARRANTY VALIDATION FORM FOR REVIEW

- **This form must be completed, submitted, and approved prior to the start-up of the Powder Coating Enclosure for warranty validation. Start-up of the Powder Coating Enclosure without a signed Warranty Validation Approval form from a Powder-X Factory Authorized Technician will immediately void the warranty.**

STEP 27 - SEE Powder Coating Enclosure START-UP PAGE